



Furniture 24" x 18" inset for bottom cabinet
1/2" x 23" rip to 23-3/8" x 17-7/8"
rout dado before *Plans.com*

Woodworking Plans You Can Download Now!

Country Style Shelf



Easy to make, this shelf makes a great place to display collectors plates, nick-knacks or treasured trophies in your children's room.

Dimensions:

5-3/4" High x 24" Wide
x 5" Deep

Getting started:

The parts for this project can be cut with a variety of tools and machines but we all have our favorites and those of which we are most comfortable. We suggest you read through the instructions before doing any cutting and decide which tools you feel most comfortable using. The plan is designed to guide you through the steps of building the project as we have.

Shop tips:

We have a few helpful hints we would like to share with you that have made assembling projects easier for us and help you to have the same success and enjoyment.

Predrilling is always a good idea in any type of wood that you use to avoid splitting or breaking off screw heads.

You can't say enough about squaring up assemblies no matter where you are in the assembly process. Getting something a little out of skew can be a frustrating experience for any woodworker. To avoid this always keep a tape measure and square handy. Remember to square before and after you have tightened the clamps.

All of the parts in this plan have been given a part number so they can be easily identified in the assembly instructions. When cutting out parts it is helpful to mark the part number (in pencil) on that part so when it comes time for assembly you can easily identify that specific part.

A note about safety:

Woodworking can be dangerous. Safety equipment and keeping your tools in proper working order with guards in place and adjusted properly can greatly reduce your risk of injury.

Be sure to read and understand all of the safety instructions that come with your tools.

Use common sense and caution in your workshop at all times. If you are not comfortable with a procedure, don't do it. Find an alternative that feels safe for you, no matter how others may work. Safety in your workshop is your responsibility.

Thank you for trying FurniturePlans.com.

If you have specific questions or problems regarding any of our plans, you may e-mail us at:

tech@furnitureplans.com

If you have any general comments or suggestions, please e-mail us at:

info@furnitureplans.com

We'll be happy to hear from you.

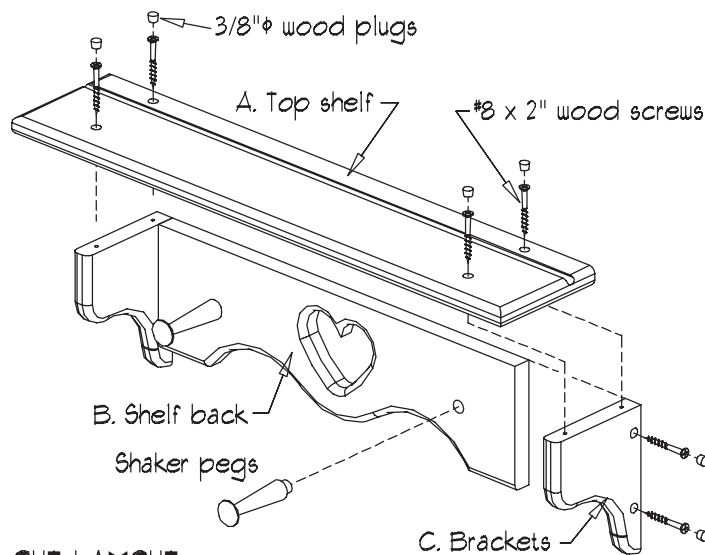

CUT LAYOUT

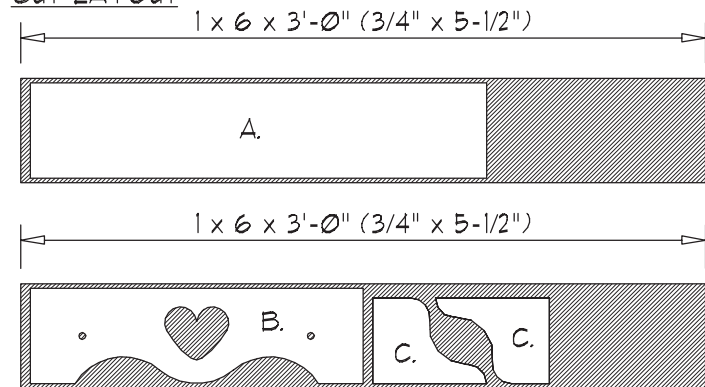

PARTS CUT LIST: (finished dimensions)

- A. (1) 5" x 24" (top shelf)
- B. (2) 5" x 17-1/2" (shelf back)
- C. (2) 6" x 4-1/2" (brackets)

HARDWARE LIST:

- #8 x 2" flathead wood screws
- 3/8" diameter wood plugs
- 1/8" diameter x 3-3/8" long shaker pegs

MATERIALS LIST:

- (2) 1 x 6 x 36"

DIAG 1. CUT AND ROUT TOP SHELF (A.)

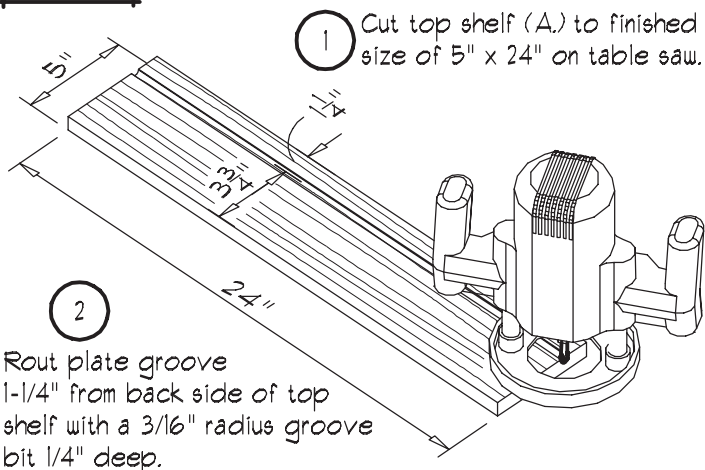

DIAG 2. DRILL COUNTERSINK HOLES

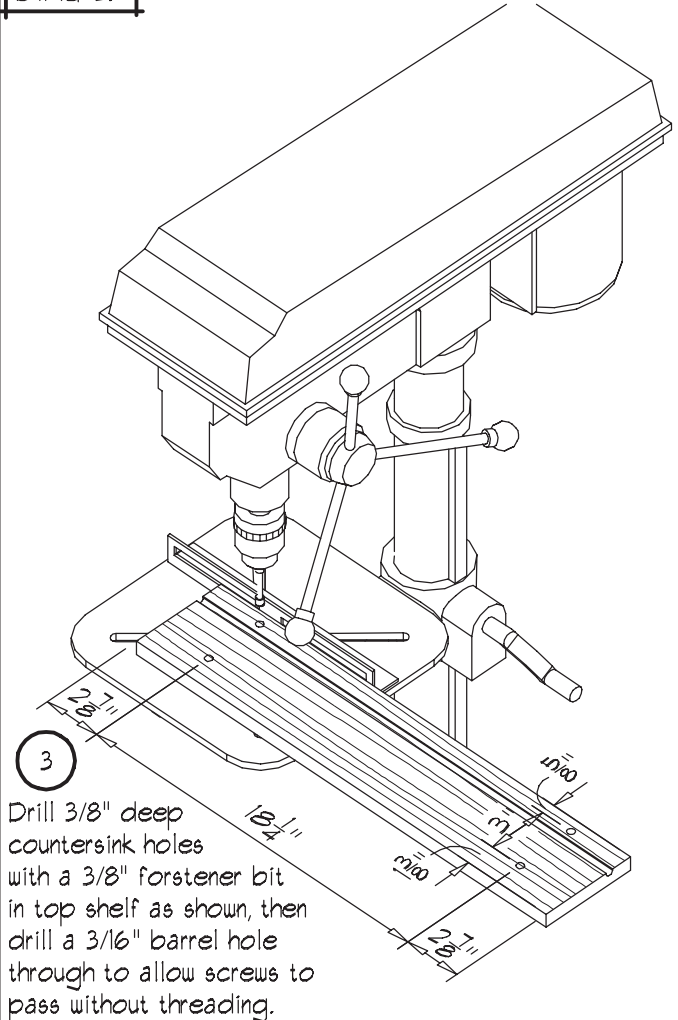

DIAG 3. EDGE ROUT TOP SHELF (A.)

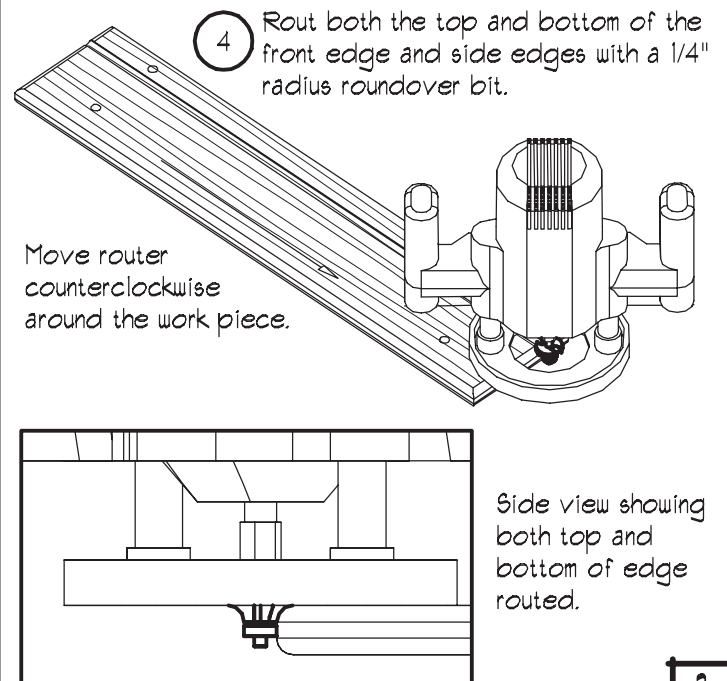

DIAG 4. CUT OUT BRACKETS (C.)

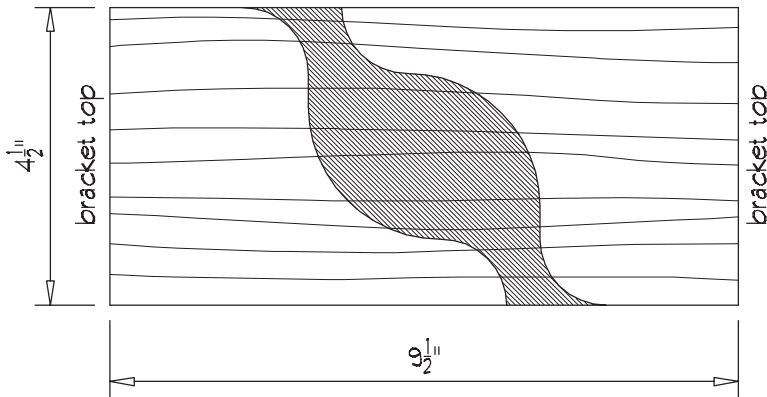

5 Use the template below to lay out the bracket pieces on a 4-1/2" x 9-1/2" wood blank. Note grain direction.

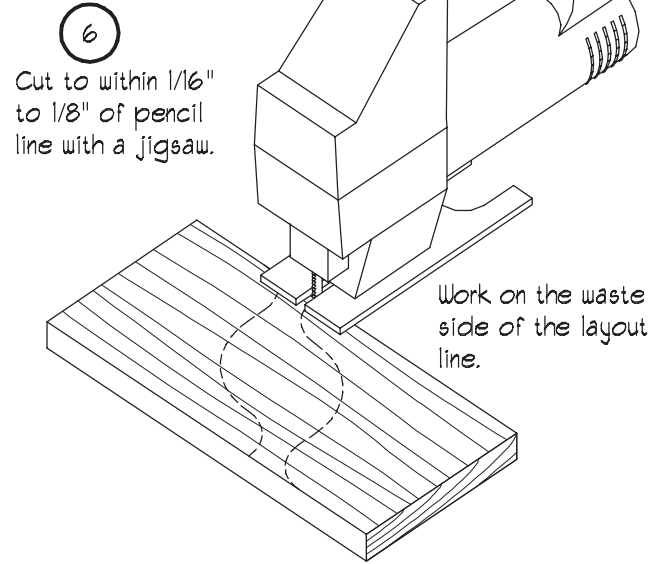

DIAG 5. BRACKET PATTERN

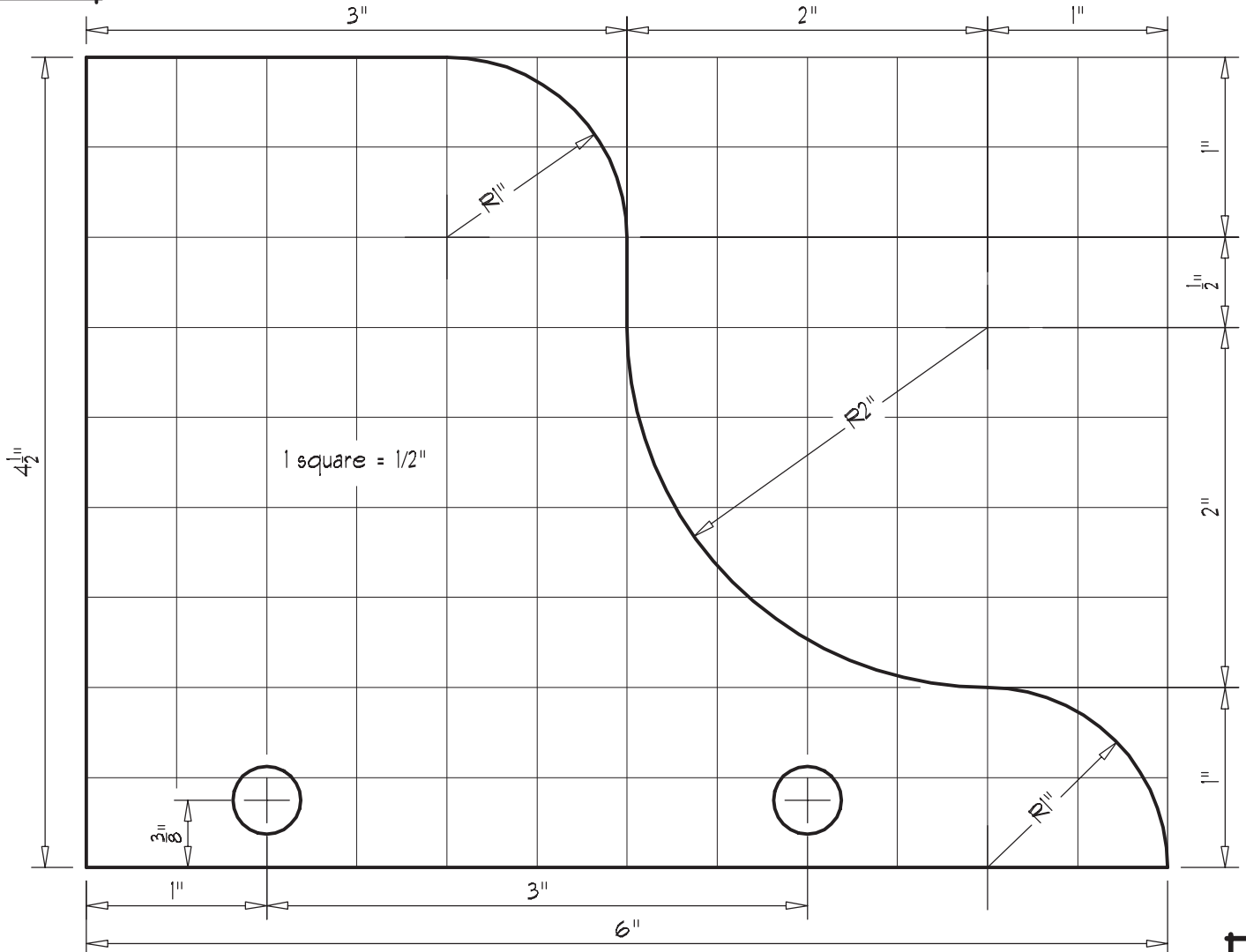

DIAG 6. SAND BRACKET CURVES

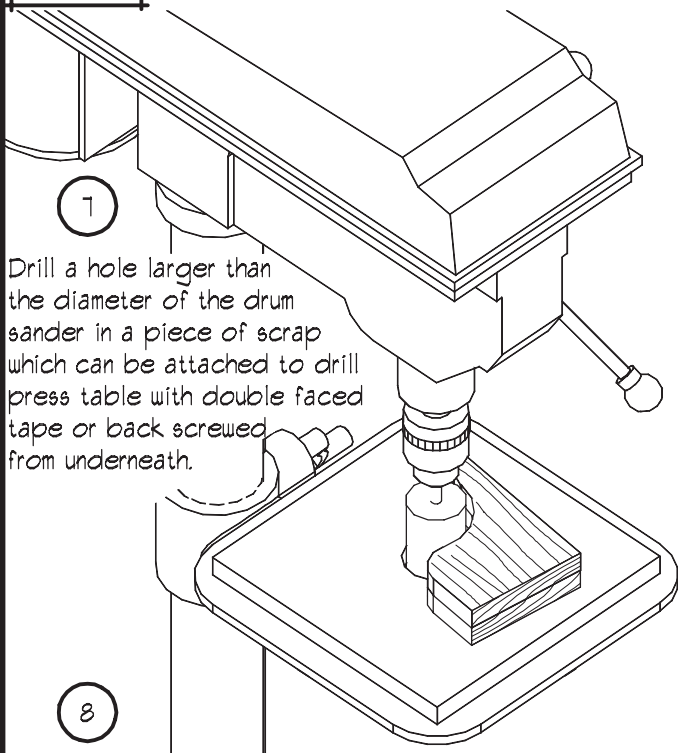

Drill a hole larger than the diameter of the drum sander in a piece of scrap which can be attached to drill press table with double faced tape or back screwed from underneath.

Use double faced tape to hold both brackets together making sure straight edges are even and sand to layout line.

DIAG 8. ROUT BRACKET EDGE

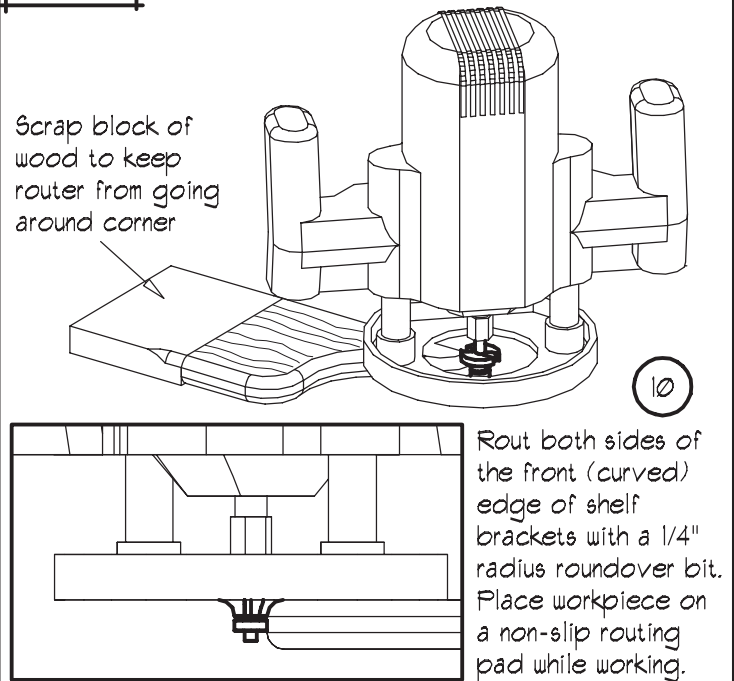

Scrap block of wood to keep router from going around corner

Rout both sides of the front (curved) edge of shelf brackets with a 1/4" radius roundover bit. Place workpiece on a non-slip routing pad while working.

DIAG 9. ROUT HANGING SLOTS

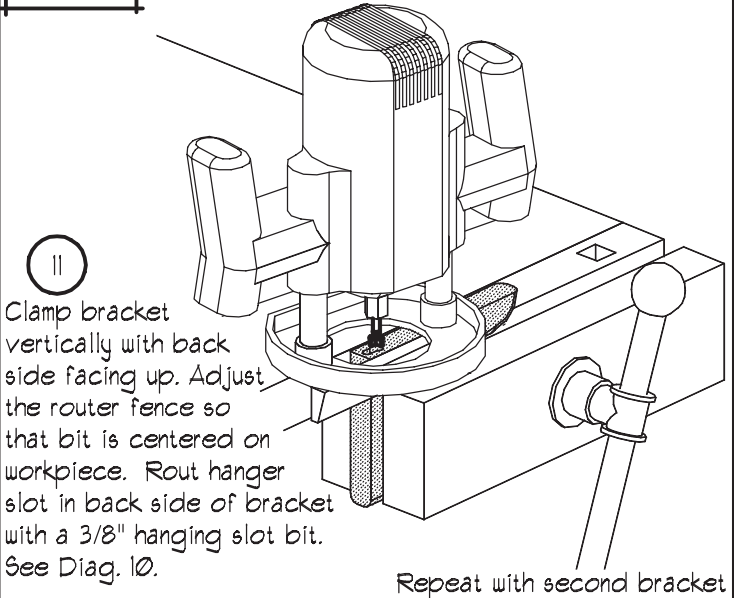

Clamp bracket vertically with back side facing up. Adjust the router fence so that bit is centered on workpiece. Rout hanger slot in back side of bracket with a 3/8" hanging slot bit. See Diag. 10.

Repeat with second bracket

DIAG 7. DRILL BRACKET HOLES

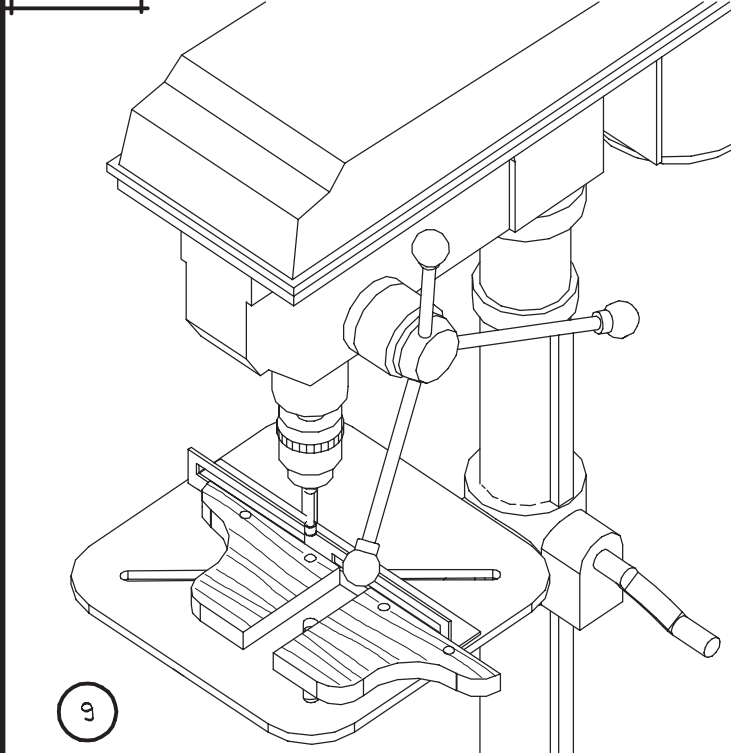

Drill 3/8" deep countersink holes with 3/8" forstener bit at locations shown on template. Be sure to drill countersink holes on the left side of the left bracket and the right side of the right bracket. Follow up by drilling a 3/16" barrel hole through to allow screws to pass without threading.

DIAG 10. HANGING SLOTS

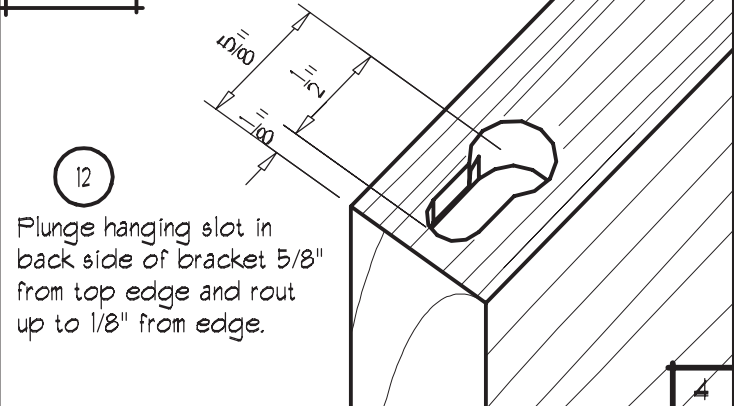

Plunge hanging slot in back side of bracket 5/8" from top edge and rout up to 1/8" from edge.

DIAG 11. CUT BACK PIECE (B.)

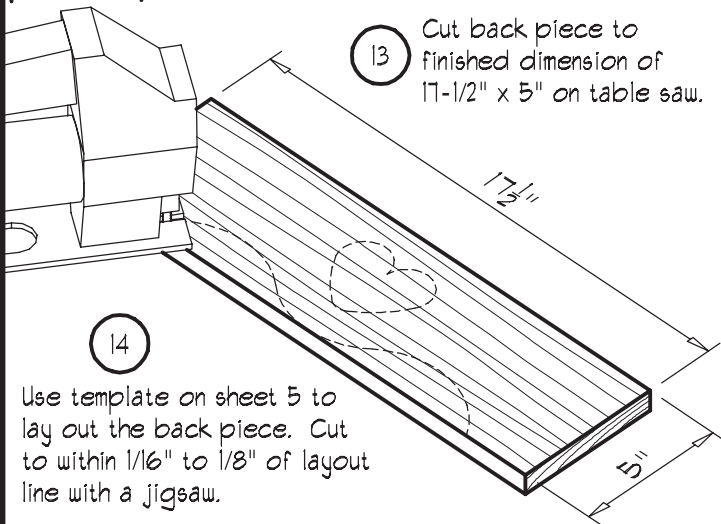

13 Cut back piece to finished dimension of 17-1/2" x 5" on table saw.

14 Use template on sheet 5 to lay out the back piece. Cut to within 1/16" to 1/8" of layout line with a jigsaw.

DIAG 12. CUT OUT HEART SHAPE

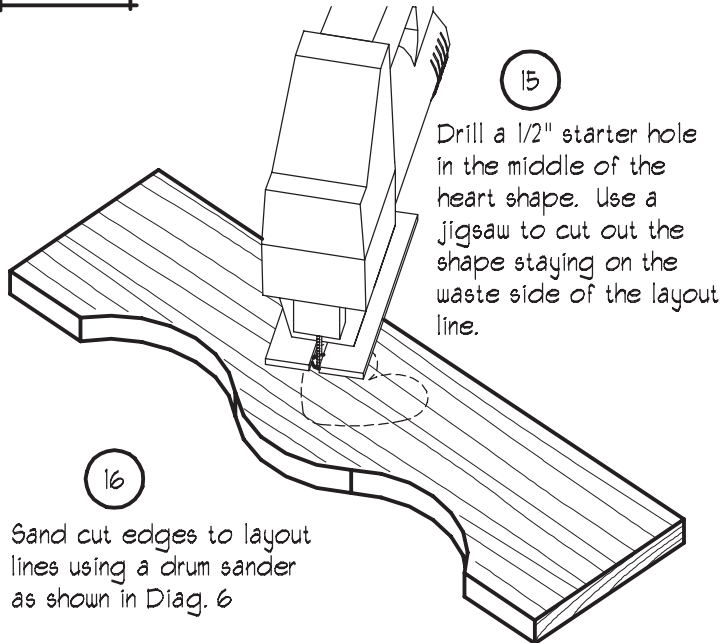

15 Drill a 1/2" starter hole in the middle of the heart shape. Use a jigsaw to cut out the shape staying on the waste side of the layout line.

16 Sand cut edges to layout lines using a drum sander as shown in Diag. 6

DIAG 14. DRILL HOLES FOR SHAKER PEGS

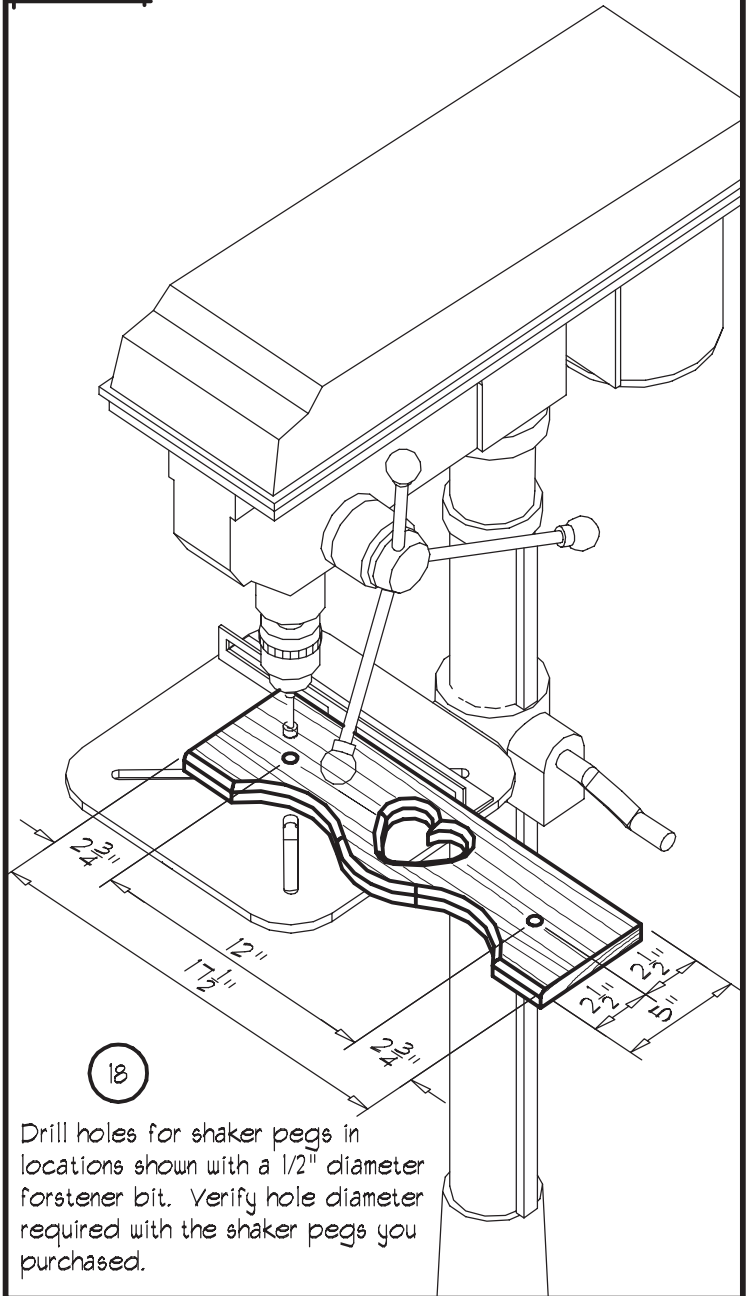

18 Drill holes for shaker pegs in locations shown with a 1/2" diameter forstener bit. Verify hole diameter required with the shaker pegs you purchased.

DIAG 13. ROUT EDGES OF BACK PIECE

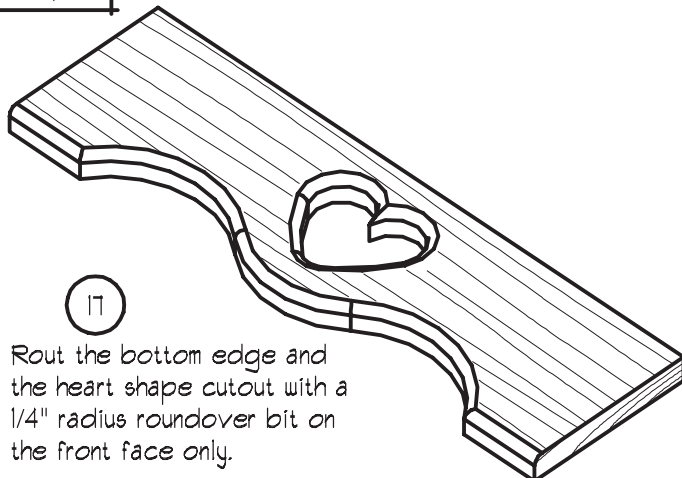

17 Rout the bottom edge and the heart shape cutout with a 1/4" radius roundover bit on the front face only.

PREPARE FOR FINAL ASSEMBLY

Now is the best time to give all the pieces a final sanding and prepare for final assembly.

Start with 150 grit sandpaper to remove all the tool marks and work your way through to 220 grit until the surface is smooth.

If you plan to use water based stain to finish the shelf, it is a good idea to lightly wet the wood surface with a damp cloth before the final sanding with 220 grit paper. This will raise any grain that would otherwise raise when a water based finish is applied.

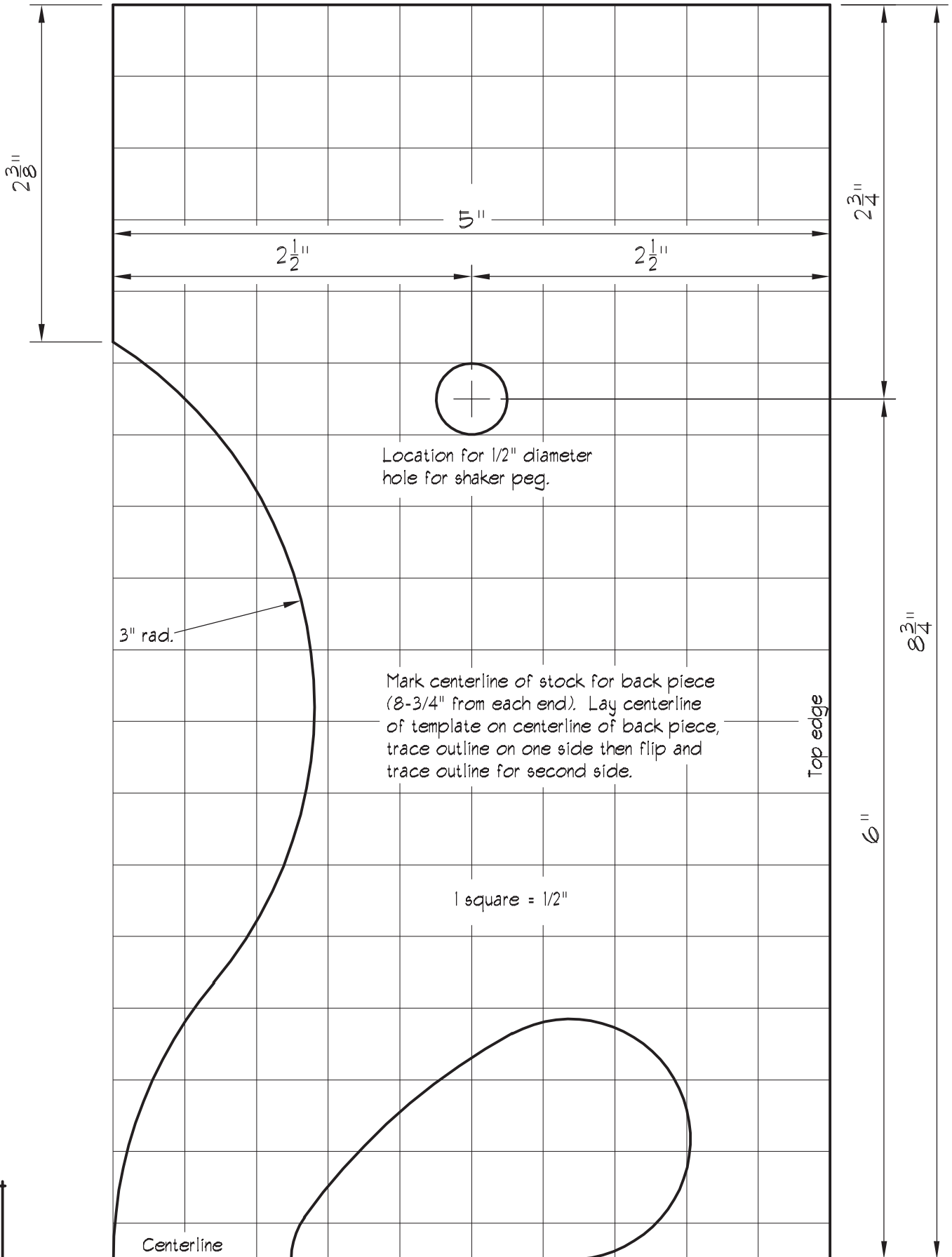

DIAG 15. BACK PIECE TEMPLATE

FINAL ASSEMBLY

19 Glue and attach brackets to back piece through pre-drilled holes with (2) #10 x 2" wood screws. Be sure top and back of brackets are flush with top and back of the back piece. Plug holes with wood plugs glued into place and sanded flush

20 Glue and attach top shelf to assembly through pre-drilled holes with (4) #10 x 2" wood screws. Be sure back of top shelf is flush with the back of the assembly. Plug holes with wood plugs glued into place and sanded flush.

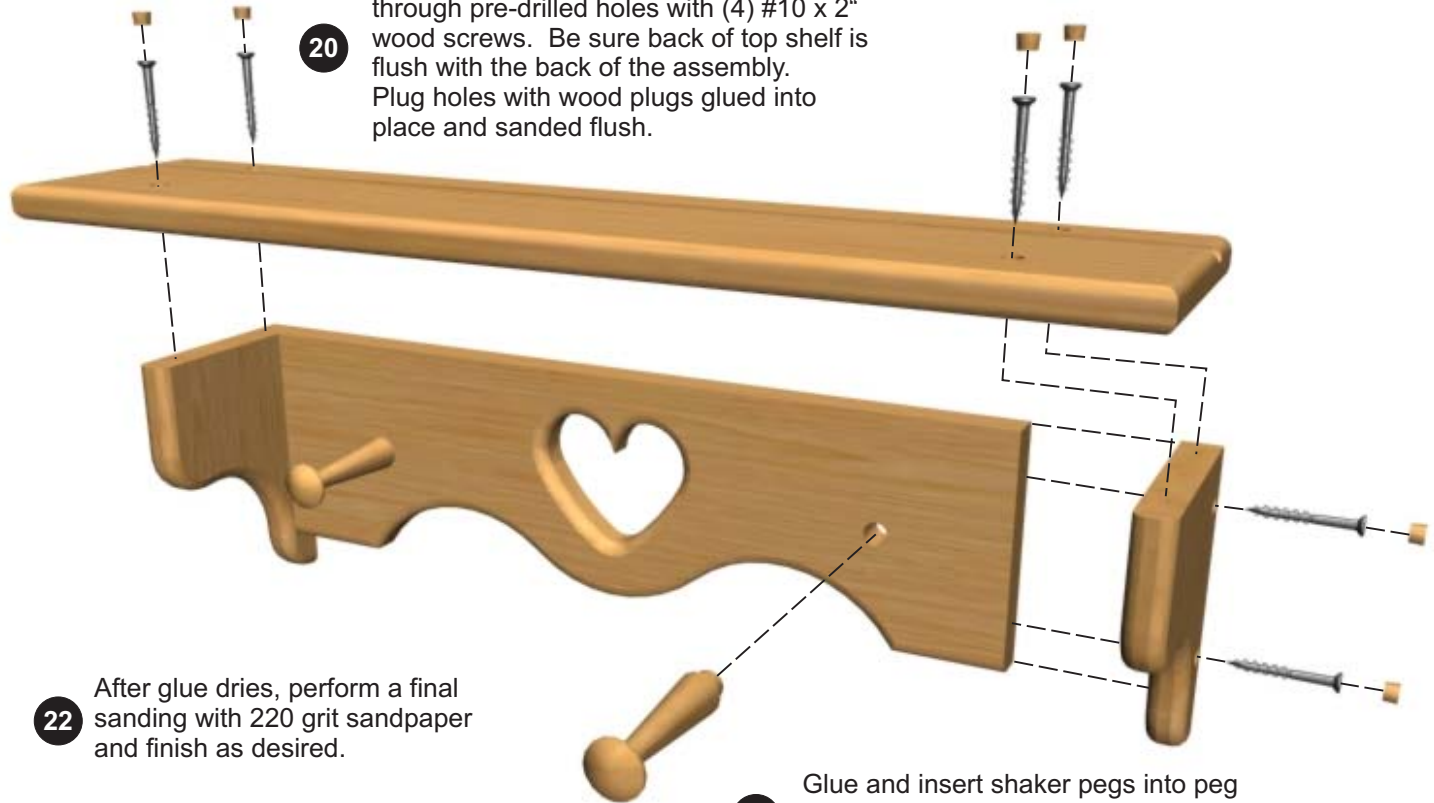

22 After glue dries, perform a final sanding with 220 grit sandpaper and finish as desired.

21 Glue and insert shaker pegs into peg holes in back piece. Be sure to wipe any excess glue immediately.